





Steps To Best Company in Concrete Industry

-  Head Office
-  Factory
-  Sales Region
-  Representative Office
-  Factory (In Progress)
-  Quarry

PRESENTATION MATERIAL

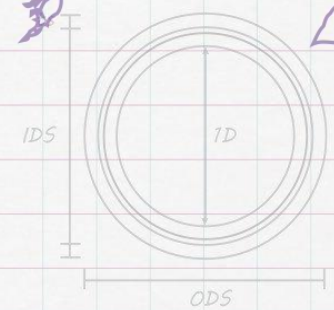
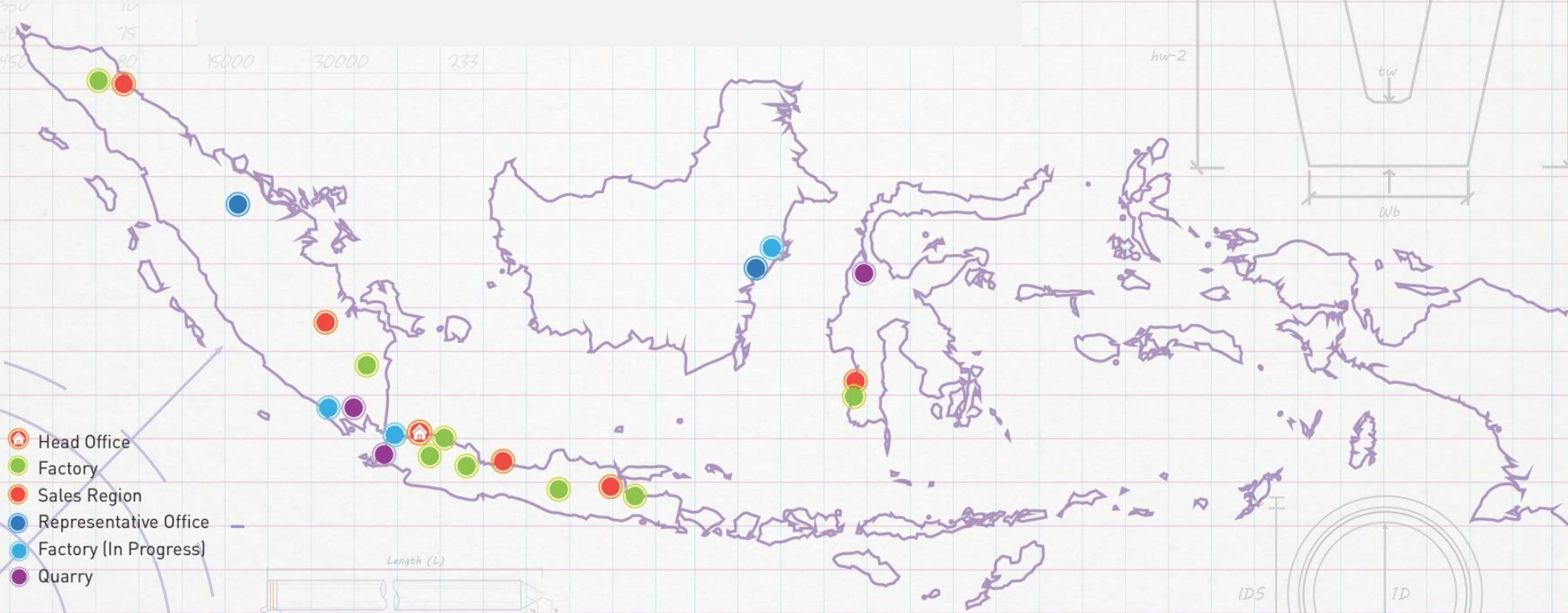
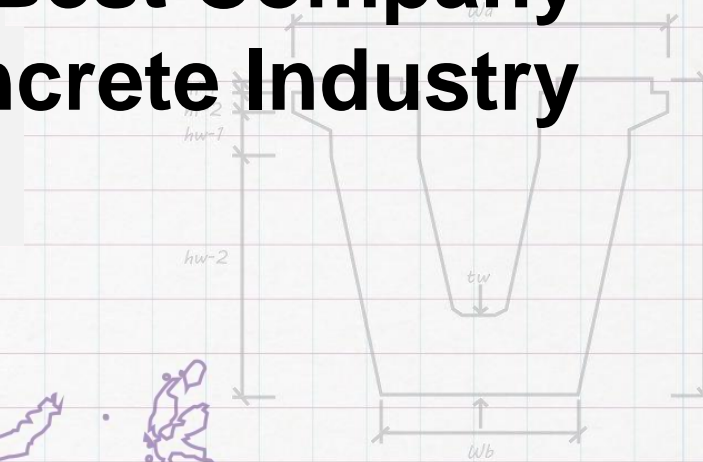

DISCLAIMER

The information that follows is a presentation of general background information about PT Wijaya Karya Beton Tbk (the “Company” or “WIKKA Beton”) prepared by the Company as of May 2014.

This presentation has been prepared for information purposes only. None of the information appearing in this presentation may be distributed to the press or other media or reproduced or redistributed in the whole or in part in any form at any time. Any recipient of this presentation and its directors, officers, employees, agents and affiliates must hold this presentation and any information provided in connection with this presentation in strict confidence and may not communicate, reproduce, distribute or disclose to any other person, or refer to them publicly, in whole or in part.

This presentation does not constitute an offer to sell or the solicitation of an offer to buy any securities in the United States or any other jurisdiction in which such offer, solicitation or sale would be unlawful prior to registration or qualification under the securities laws of any such jurisdiction, and neither this presentation nor anything contained herein shall form the basis of or be relied on in connection with any contract or commitment whatsoever. No securities may be offered or sold in the United States absent registration or an applicable exemption from registration requirements. Any public offering of securities to be made in the United States will be made by means of a prospectus. Such prospectus will contain detailed information about the company making the offer and its management and financial statements. No public offer of securities is to be made by the Company in the United States. This presentation may contain forward-looking statements and estimates with respect to the future operations and performance of the Company and its affiliates. Investors and security holders are cautioned that forward-looking statements are subject to various assumptions, risks and uncertainties, many of which are difficult to predict and are generally beyond the control of the Company. Such assumptions, risks and uncertainties could cause actual results and developments to differ materially from those expressed in or implied by the forward-looking statements.

Accordingly, no representation or warranty, either expressed or implied, is provided in relation to the accuracy, completeness or reliability of the information contained in this presentation, nor is it intended to be a complete statement or summary of the resources markets or developments referred to in this presentation. It should not be regarded by recipients as a substitute for the exercise of their own judgment.

Neither the Company or any other person assumes responsibility for the accuracy, reliability and completeness of the forward-looking statements contained in this presentation. The forward-looking statements are made only as of the date of this presentation. The Company is under no duty to update any of the forward-looking statements after this date to conform such statements to actual results or developments or to reflect the occurrence of anticipated results or otherwise.

By accepting delivery of this presentation, the recipient agrees to accept and be bound by the statements, restrictions and limitations set forth herein.

DAFTAR ISI

1	PROFIL PERUSAHAAN
2	PERTIMBANGAN INVESTASI
3	SEKILAS BISNIS & INDUSTRI
4	IKHTISAR KEUANGAN
5	INFO TERKINI PERUSAHAAN



1

PROFIL PERUSAHAAN

Visi, Misi dan Nilai-nilai

Visi

“Menjadi Perusahaan Terbaik dalam Industri Beton Pracetak”

Misi

1. Memimpin pasar beton pracetak di Asia Tenggara.
 2. Memberikan pelayanan terbaik kepada pelanggan dengan kesesuaian mutu, ketepatan waktu dan harga bersaing.
 3. Menerapkan sistem manajemen dan teknologi yang dapat memacu peningkatan efisiensi, konsistensi mutu, keselamatan dan kesehatan kerja yang berwawasan lingkungan.
 4. Tumbuh dan berkembang bersama mitra kerja secara sehat dan berkesinambungan.
 5. Mengembangkan kompetensi dan kesejahteraan pegawai.
-

Nilai-nilai
(CIBERTI)

Commitment

Balance

Relationship

Integrity

Innovation

Excellence

Teamwork

TONGGAK PENCAPAIAN **PERSEROAN(1/2)**

WIKA Beton sebagai Unit Usaha WIKA

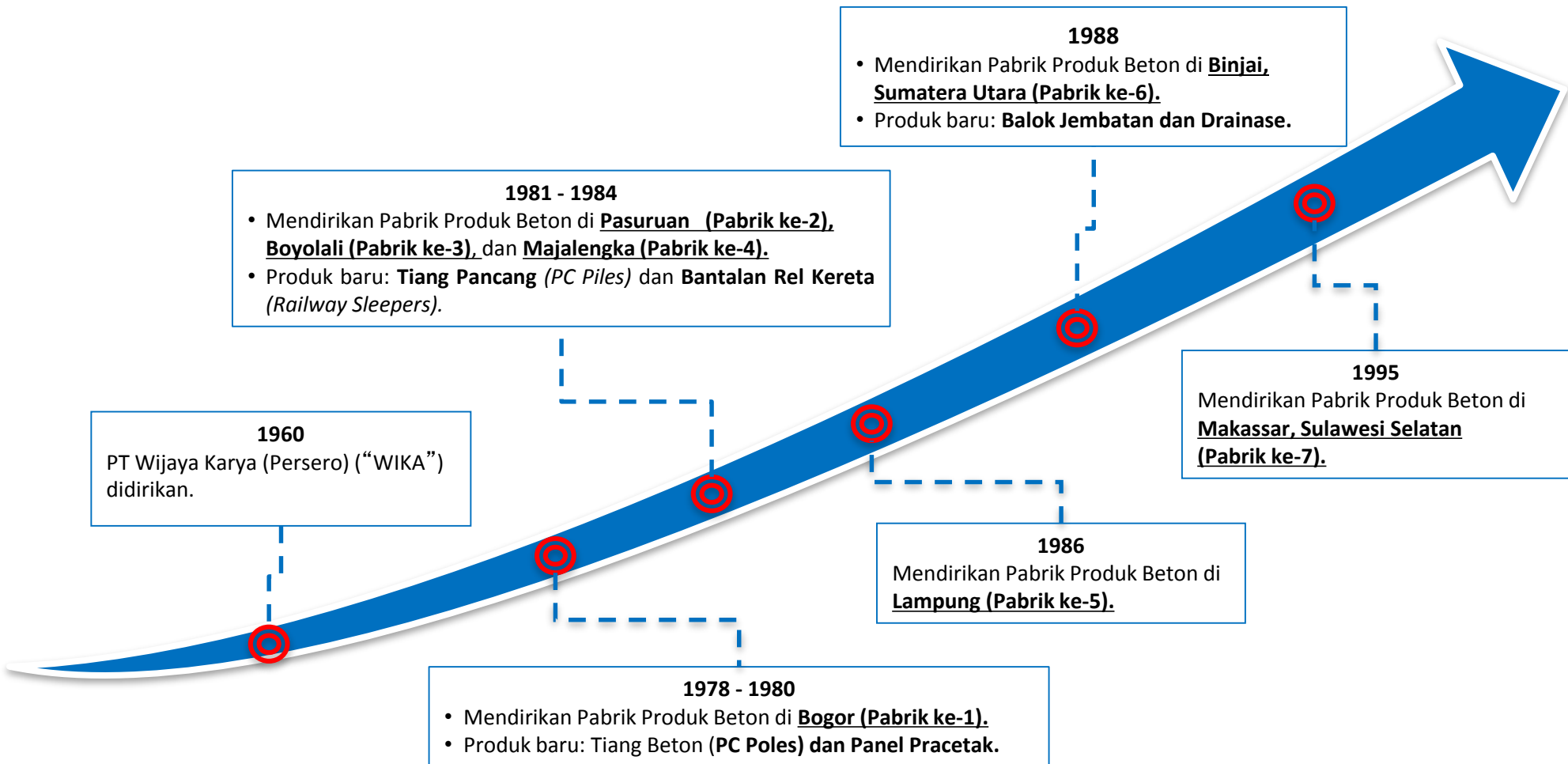

TONGGAK PENCAPAIAN **PERSEROAN(2/2)**

Wika Beton sebagai Unit Usaha Wika

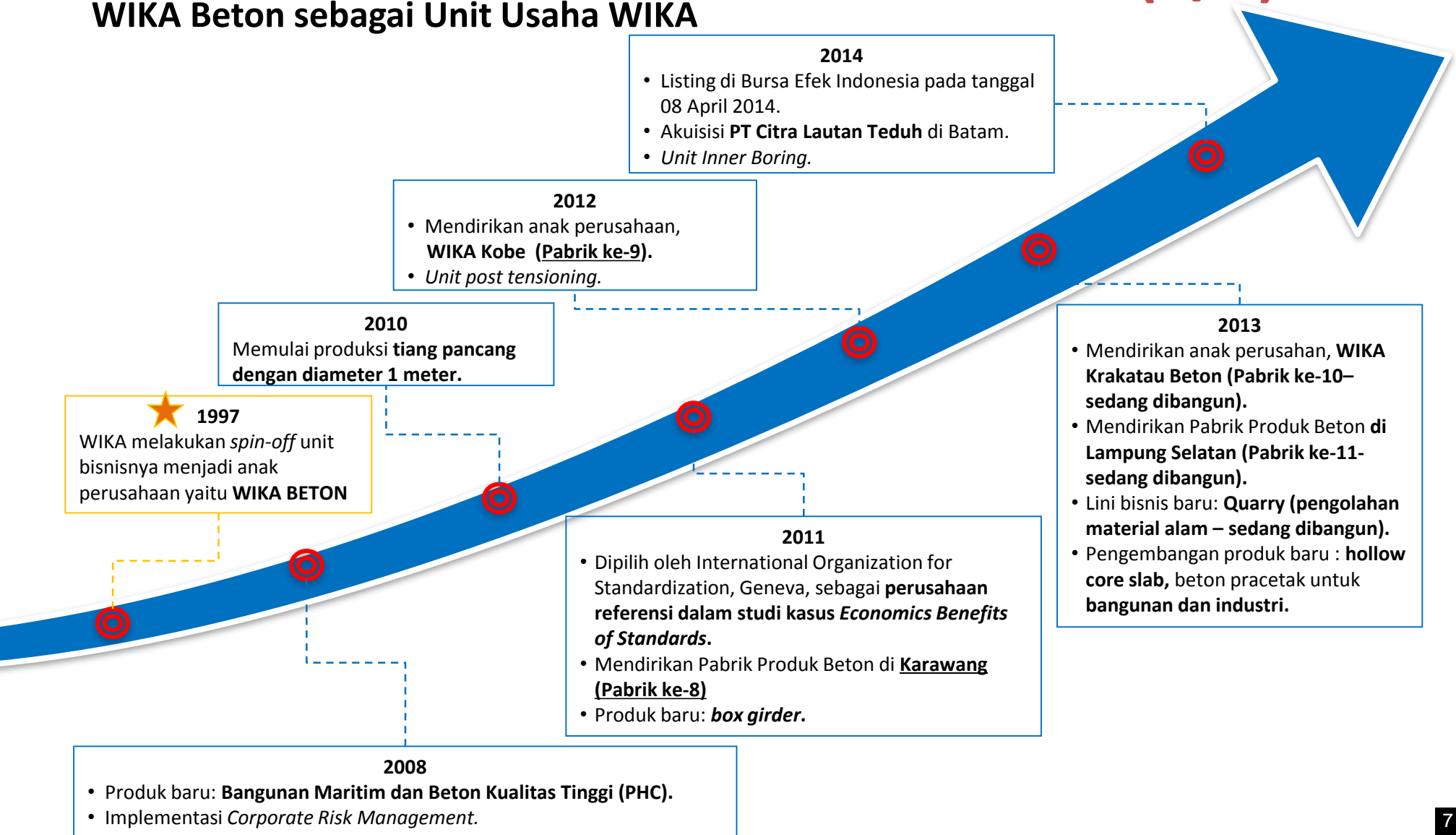

MANAJEMEN **PERSEROAN**

DEWAN KOMISARIS



Budi Harto
Komisaris Utama



A. Boediono
Komisaris



Nariman Prasetyo
Komisaris



Tumik Kristianingsih
Komisaris



Asfiah Mahdiani
Komisaris Independen



Priyo Suprobo
Komisaris Independen

DIREKSI



Wilfred I. A. Singkali
Direktur Utama



Hadian Pramudita
Direktur



Entus Asnawi Mukhson
Direktur



Fery Hendriyanto
Direktur



Hari Respati
Direktur



M. Zulkarnain
Direktur Independen

STRUKTUR KEPEMILIKAN SAHAM DI ANAK PERUSAHAAN



DAFTAR PEMEGANG SAHAM

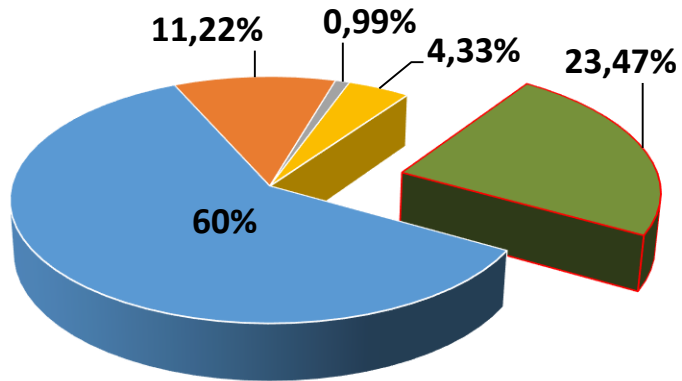

- PT Wijaya Karya (Persero) Tbk
- Koperasi Karya Mitra Satya
- Yayasan Wijaya Karya
- Treasury Stock
- Publik

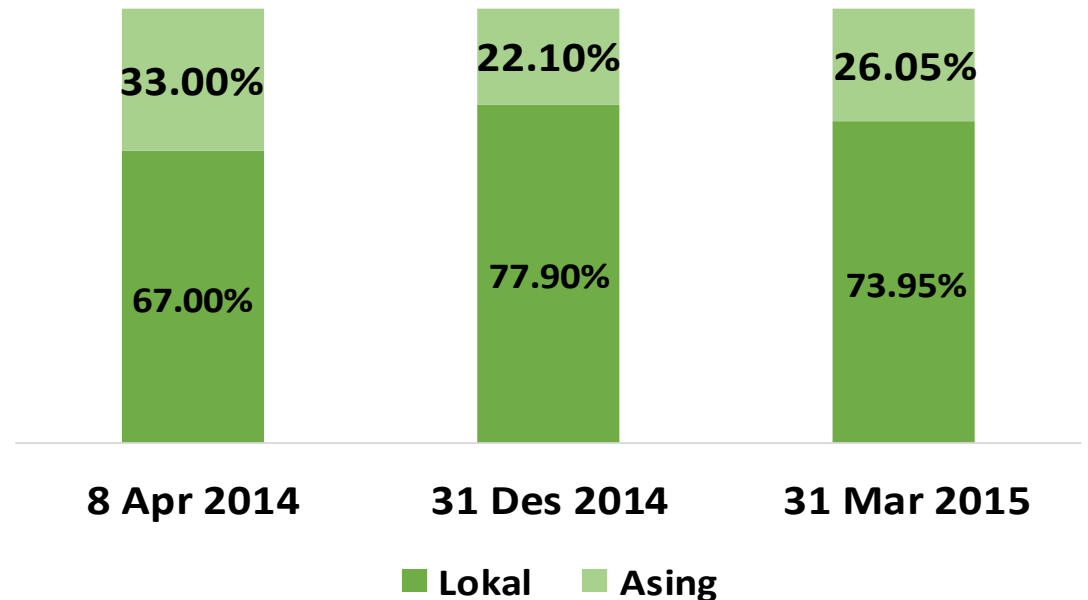



2

PERTIMBANGAN INVESTASI

PERTIMBANGAN INVESTASI



1 Kapasitas Produksi Terbesar dan Pemimpin Pangsa Pasar untuk Mencapai Skala Ekonomis

- Berdasarkan riset MARS, surveyor independen, di Januari 2014, terdapat **28 pabrik beton pracetak di Indonesia yang dimiliki oleh 20 perusahaan dengan kapasitas 5,2 juta ton per tahun**, dimana 89,3% dari total kapasitas didominasi oleh 9 perusahaan.
- **WIKA Beton memiliki kapasitas produksi terbesar dengan 2 juta ton per tahun atau 38,6% dari total kapasitas produksi Indonesia.**
- **Pangsa pasar WIKA Beton di 2013 diperkirakan sebesar 42,7%.**

Rincian Kapasitas Produksi Beton Pracetak di Indonesia

Pangsa Pasar WIKA Beton Berdasarkan Penjualan (2013)

WIKA Beton dapat mencapai skala ekonomis dibandingkan kompetitornya melalui kapasitas produksi.

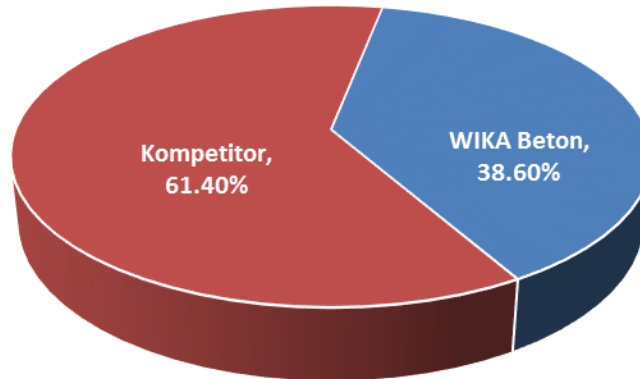

Sumber: MARS

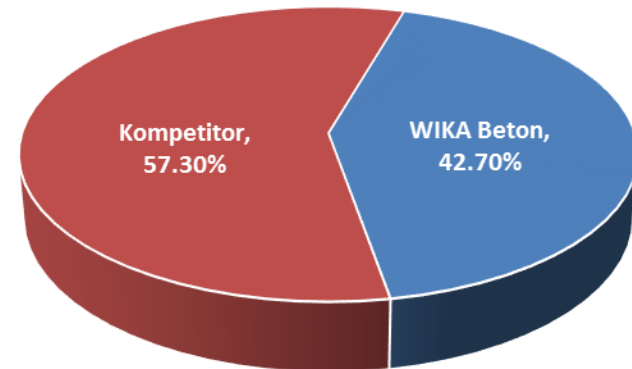

Sumber: BCI Asia

2 Wilayah Cakupan yang Luas dan Pabrik yang Terintegrasi di Seluruh Indonesia

- **Cakupan yang Luas:** WIKA Beton akan memiliki 11 pabrik produk beton di akhir tahun 2014 (termasuk anak perusahaan), 6 wilayah pemasaran dan 2 kantor representatif yang strategis diseluruh Indonesia.
- **Terintegrasi:** 1) Siklus bisnis yang menyeluruh dari produksi bahan baku, barang jadi dan jasa bagi pelanggan (*Backward and Forward Integration*); 2) Fleksibilitas dalam mendistribusikan fasilitas-fasilitas penunjang seperti cetakan dan lain-lain ke seluruh pabrik produk betonnya di seluruh Indonesia.

WIKa Beton memberikan pengiriman tepat waktu dan biaya transportasi yang ekonomis melalui pendekatan dengan pelanggannya.

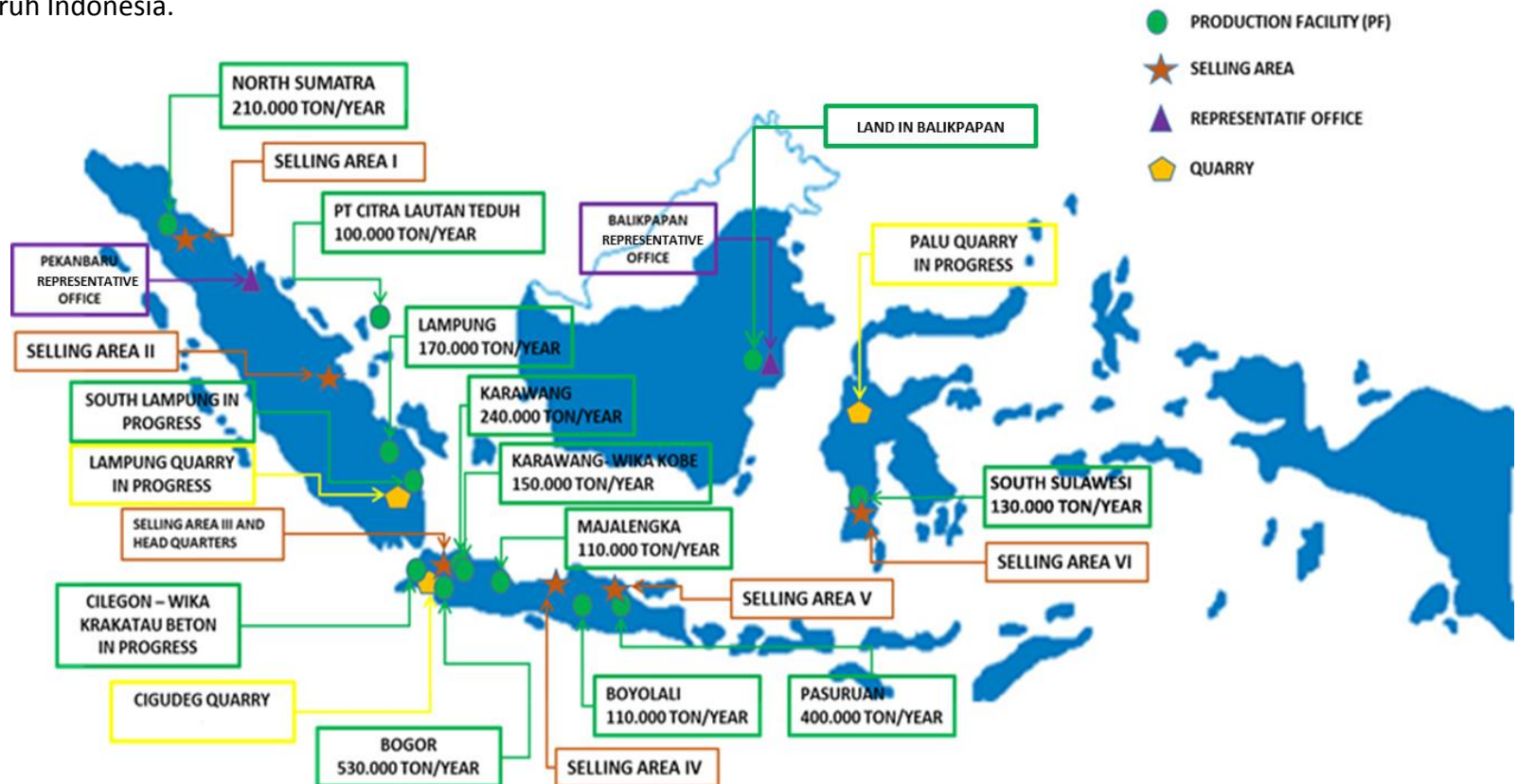

Manajemen yang Berpengalaman dan Memiliki Rekam Jejak yang Baik dalam Industri Beton Pracetak

3

Berpengalaman lebih dari 20 tahun di industri beton pracetak dan industri terkait



Wilfred I. A. Singkali
Direktur Utama

Berpengalaman 31 tahun dalam industri pracetak

- Direktur Utama Perseroan sejak 2012.
- Sebelumnya menjabat sebagai Direktur Teknik dan Produksi Perseroan (2007 – 2012).
- Memulai karirnya dengan PT Wijaya Karya (Persero) Tbk sebagai Staf Litbang Biro Engineering (1983).



Hadian Pramudita
Direktur

Berpengalaman 27 tahun dalam industri pracetak

- Direktur Pemasaran Perseroan sejak 2012.
- Sebelumnya menjabat sebagai Manajer Pemasaran (2008 – 2012).
- Memulai karirnya dengan PT Wijaya Karya (Persero) Tbk sebagai Staf Teknik (1987).



Entus Asnawi Mukhson
Direktur

Berpengalaman 26 tahun dalam keuangan sektor konstruksi

- Direktur Keuangan dan Sumber Daya Manusia Perseroan sejak 2011.
- Sebelumnya menjabat sebagai *General Manager* bidang keuangan di PT Wijaya Karya (Persero) Tbk.
- Memulai karirnya dengan PT Wijaya Karya (Persero) Tbk sebagai Staf Akuntansi dan Keuangan (1988).



Fery Hendriyanto
Direktur

Berpengalaman 21 tahun dalam industri pracetak

- Direktur Operasional I Perseroan sejak 2012.
- Sebelumnya menjabat sebagai Manajer Pengendalian Operasi Perseroan (2007 – 2012).
- Memulai karirnya dengan PT Wijaya Karya (Persero) Tbk sebagai *Sales Engineer* (1993).



Hari Respati
Direktur

Berpengalaman 31 tahun dalam industri konstruksi

- Direktur Operasional II Perseroan sejak 2013.
- Sebelumnya menjabat sebagai Direktur Operasional Perseroan, beliau bekerja untuk PT Wijaya Karya (Persero) Tbk sebagai *General Manager* Departemen Konstruksi.
- Memulai karirnya dengan PT Wijaya Karya (Persero) Tbk sebagai Pelaksana Proyek di Mataram (1983 – 1984).



M. Zulkarnain
Direktur Independen

- Direktur Independen Perseroan sejak Maret 2014.
- Sebelumnya menjabat sebagai Kepala Bagian Standarisasi PT Wijaya Karya Beton (2010).
- Memulai karirnya dengan PT Wijaya Karya CAB VIII Surabaya sebagai Staff Teknik (1978 – 1979).

4

Pelopori di Produk Beton Pracetak Indonesia dengan Inovasi

WIKa Beton berkomitmen dalam meningkatkan kualitas produk dan kepuasan pelanggan melalui inovasi

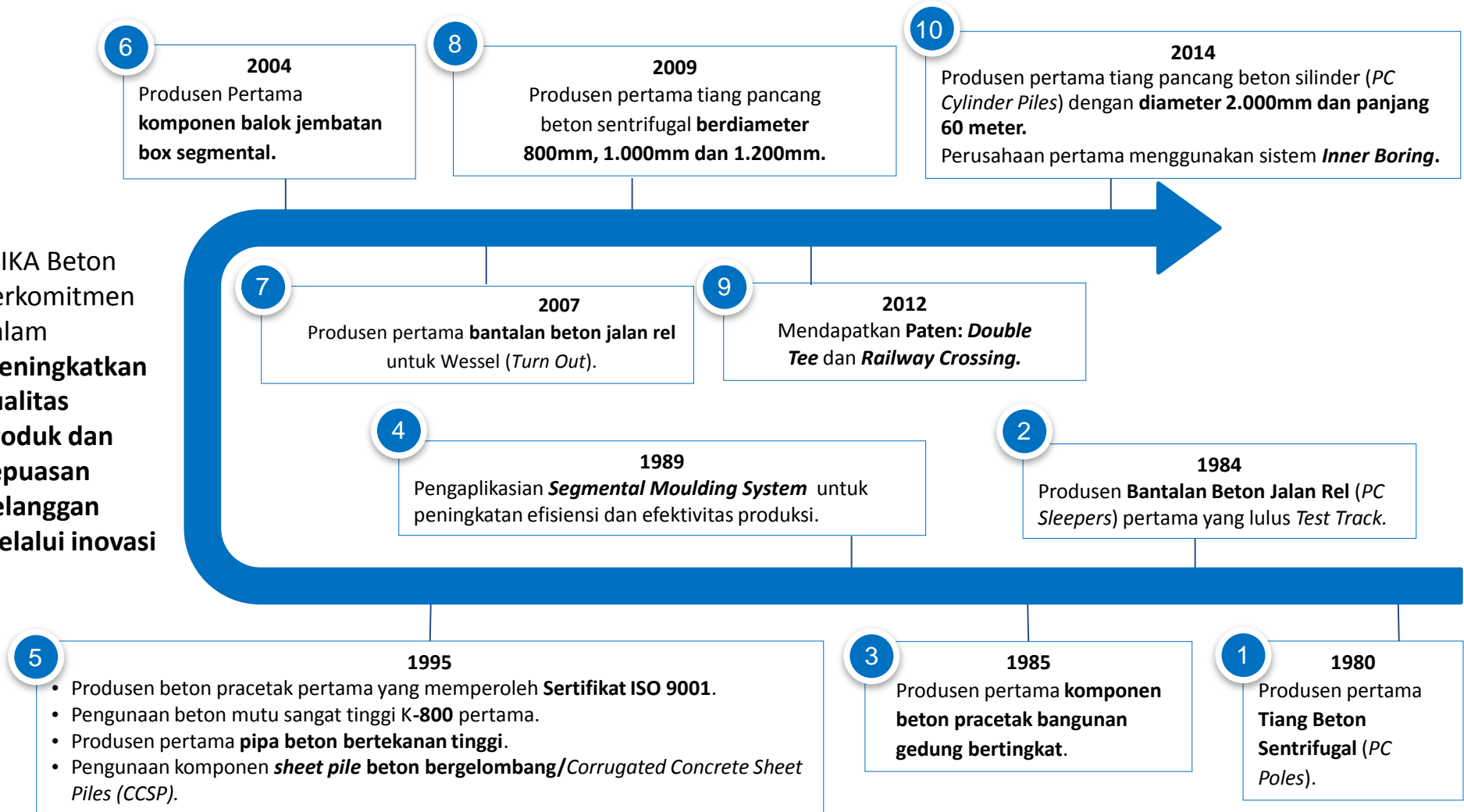

5 Aneka Produk Terlengkap di Indonesia

WIKA Beton memiliki **aneka produk terlengkap** untuk mencakup permintaan pelanggan di industri beton pracetak

1. Tiang Beton (PC Poles)



Tiang listrik distribusi, tiang listrik transmisi, tiang telepon, tiang lampu, dan tiang jaring.

2. Tiang Pancang (PC Piles)



Tiang pancang bulat sentrifugal & segi empat sentrifugal (*spinning method*) dan tiang pancang segi empat & segitiga (*vibration method*).

3. Jembatan (Bridge Concrete)



I-Girder, U girder, Box girder, Voided slab, Concrete diaphragm, Half slab and Double Tee

4. Bantalan Rel Kereta (Railway Sleepers)



KA-Clips, DE-Clips, Pandrol, E-Clips, and Vossloch

5. Dinding Penahan Tanah (Sheet Piles)



Corrugated concrete (CCSP) dan Flat sheet piles (FCSP).

6. Bangunan Air (Hydro Structure)



Core Type prestressed concrete pipes (PC pipes) and Reinforced Concrete Pipes (RC Pipes).

7. Bangunan Maritim (Marine Structure)



Produk untuk proyek –proyek dermaga dan laut lepas seperti *jetty*, jembatan, *breakwater*, dll.

8. Bangunan Gedung dan Perumahan



Dinding pracetak, slab, kolom, balok, tangga dan komponen struktur lainnya.

9. Produk Beton Lainnya



Pipe racks untuk perusahaan minyak, *water storage* dan *water-cooling towers* untuk pembangkit listrik

10. Jasa



Enjiniring, pemasangan, distribusi, dan konstruksi.



3

a. SEKILAS INDUSTRI

PEMBANGUNAN INFRASTRUKTUR JOKOWI 2015-2019

LOKASI 15 BANDARA DAN 24 PELABUHAN



- Jalan baru **2.650 Km**
- Jalan tol **1.000 Km**
- Pemeliharaan jalan **46.770 Km**



- Pembangunan Jalur KA **3.258 Km** di Jawa, Sumatera, Sulawesi dan Kalimantan terdiri dari: KA Antar kota 2.159 Km, KA Perkotaan 1.099 Km



- Pembangunan **15 Bandara baru**
- Pengadaan **20 Pesawat Perintis**
- Pengembangan Bandara untuk pelayanan **Cargo Udara** di **6 Lokasi**



- Pembangunan Pelabuhan Penyeberangan di **60 Lokasi**
- Pengadaan **Kapal penyeberangan perintis sebanyak 50 unit**



- Pembangunan **24 Pelabuhan baru**
- Pengadaan **26 Kapal Barang Perintis**
- Pengadaan **2 Kapal Ternak**
- Pengadaan **500 unit Kapal rakyat**



- Pembangunan **BRT di 29 kota**
- Pembangunan angkutan massal cepat di kawasan perkotaan (**6 Kota metropolitan, 17 Kota besar**)

SUMBER: BAPPENAS / INFOGRAFIS: ANDHIKA AKBARYANSYAH/DETIKCOM

KEBUTUHAN INVESTASI INFRASTRUKTUR RPJMN 2015-2019

KEPERLUAN INVESTASI INFRASTRUKTUR RPJMN 2015-2019 (Rp triliun)						
Sektor	Skenario Penuh (100%)	Skenario Parsial (75%)		Skenario Dasar (50%)		
		Kebutuhan	Proporsi pada 100%	Kebutuhan	Proporsi pada 100%	
Jalan Raya	1274	851	67%	637	50%	
Perkeretaapian	278	222	80%	140	50%	
Transportasi Perkotaan	166	115	69%	75	45%	
Transportasi Laut	563	424	75%	282	50%	
Ferry and ASDP	91	80	88%	60	66%	
Transportasi Udara	182	165	91%	100	55%	
Ketenagalistrikan	1,080	762	71%	714	66%	
Energi and Gas	535	420	79%	268	50%	
Sumber Daya Air	1,091	845	77%	645	59%	
Air Bersih dan Limbah	666	450	68%	330	50%	
Perumahan Rakyat	384	247	64%	180	47%	
Teknologi Komunikasi dan Informatika	242	200	83%	130	54%	
Jumlah	6,552	4,781		3,561		

Keperluan Investasi (Prioritas)

5,452



3

b. SEKILAS BISNIS

KAPASITAS PRODUKSI 2008 - 2018

- Saat ini Perseroan memiliki kapasitas terpasang sebesar 2,2 juta ton per tahun.
- Perseroan berencana meningkatkan kapasitas terpasang 210% dari tahun 2008-2018.

Kapasitas Terpasang (Juta Ton Per Tahun)

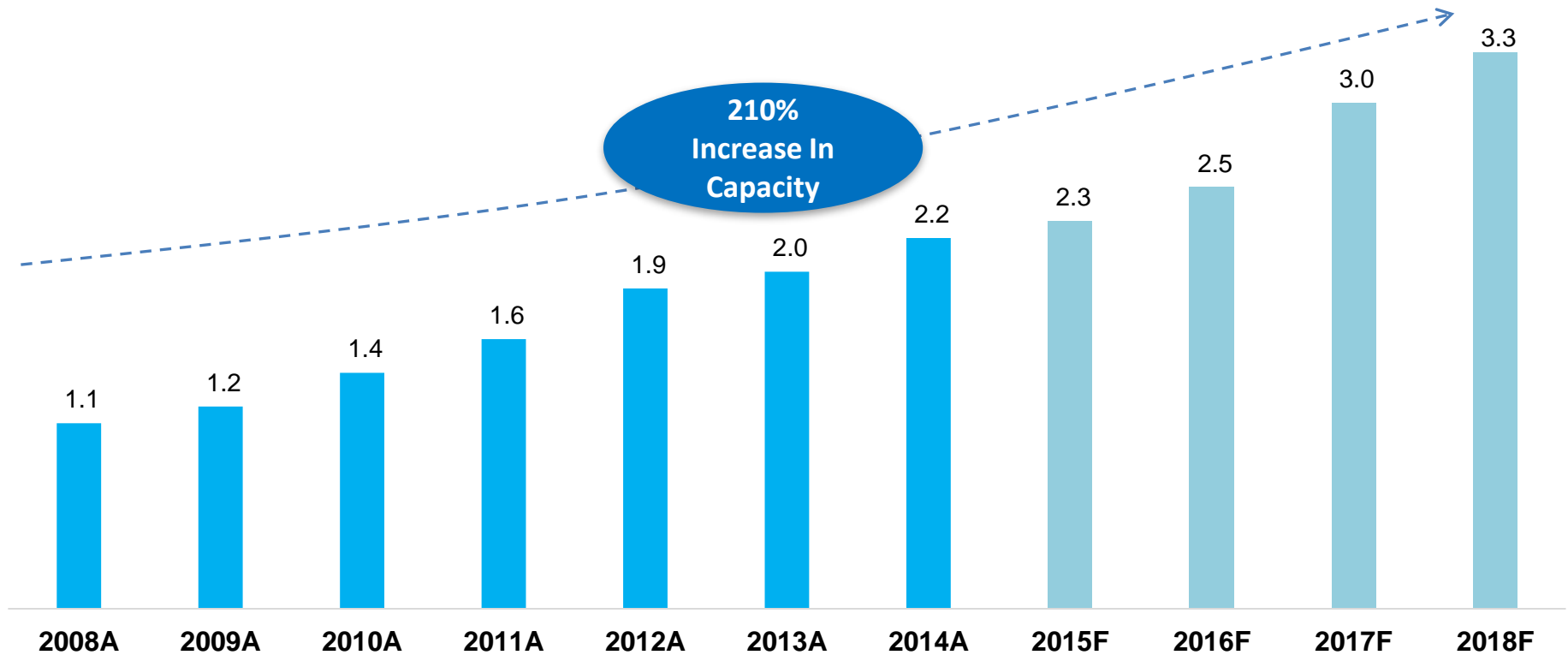

PROFIL PELANGGAN

- Berdasarkan lini usaha, kontribusi pendapatan WIKA Beton terbesar di tahun 2014 berasal dari **sektor infrastruktur sebesar 44%**.
- Berdasarkan kepemilikannya, kontribusi pendapatan WIKA Beton terbesar berasal dari **swasta – lokal sebesar 69%** diikuti **dengan perusahaan BUMN sebesar 22%**.
- Kontribusi dari WIKA di tahun 2014 sebesar 8%.

10 Pelanggan Terbesar di 2014

No	Pelanggan	Kontribusi
1.	PT Wijaya Karya (Persero) Tbk	8%
2.	PT Perusahaan Listrik Negara (Persero)	4%
3.	PT Waskita Karya (Persero)	4%
4.	PT Hutama Karya (Persero)	4%
5.	PT Pembangunan Perumahan (Persero) Tbk	4%
6.	PT Energi Sejahtera Mas	4%
7.	PT D & C Engineering	3%
8.	PT Multi Artha Pratama	2%
9.	PT Kawahapejaya Indonesia	2%
10.	PT Sinar Menara Deli	2%

Profil Pelanggan Berdasarkan Lini Usaha di 2014 (Persen dari Pendapatan)

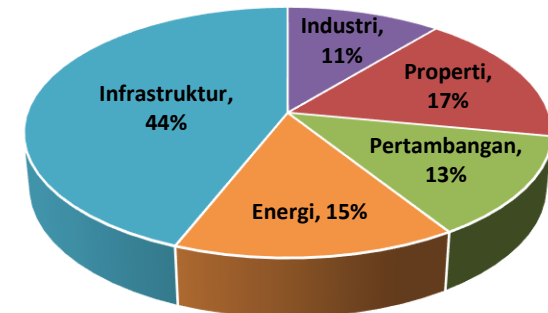

Profil Pelanggan Berdasarkan Kepemilikan di 2014 (Persen dari Pendapatan)

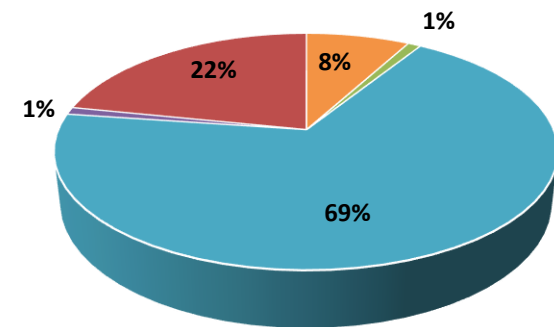

- Wika
- Swasta-Lokal
- BUMN
- Swasta-Asing
- Pemerintah Indonesia

LANDMARK PROJECTS

Jalan & Jembatan

Jembatan Pasupati
(2004)



Jembatan Cikubang –
Cipularang (2006)



Jembatan Suramadu
(2008)



East West Motorway Project –
ALGERIA (2011)



Jalan & Jembatan (Lanjutan)

Double Track Cirebon –
Kroya (2012)



Tol Bali
(2013)



Overpass Kamp. Melayu –
Tanah Abang (2014)



Power Plant

Power Plant di Semen Tonasa
(2010)



PLTU Cirebon
(2011)



Pelabuhan

Malayahati - Aceh (2006)
Decorient//BAM – Dutch*



Oil & Gas

Drajat Cooling Tower – Garut (2005)
Thiess*



Gorgon Project – BARROW, AUSTRALIA (2012)
Saipem SA*



Pipe Rack RFCC for Oil – Cilacap (2013)
GS – Korea*



*Pelanggan Internasional



4

IKHTISAR KEUANGAN

ORDER BOOK & REVENUE

- Total *Order Book* adalah penambahan *new order book* dengan *carry over* dari tahun sebelumnya.
- Carry Over dari tahun sebelumnya dapat menjamin jumlah *revenue* yang dihasilkan pada tahun berikutnya.
- Wika Beton mempunyai estimasi *revenue* sebesar Rp1,63 triliun di 2014 hanya dari *carry over* di 2013.

Total Order Book Vs. Revenue (Rp Miliar)

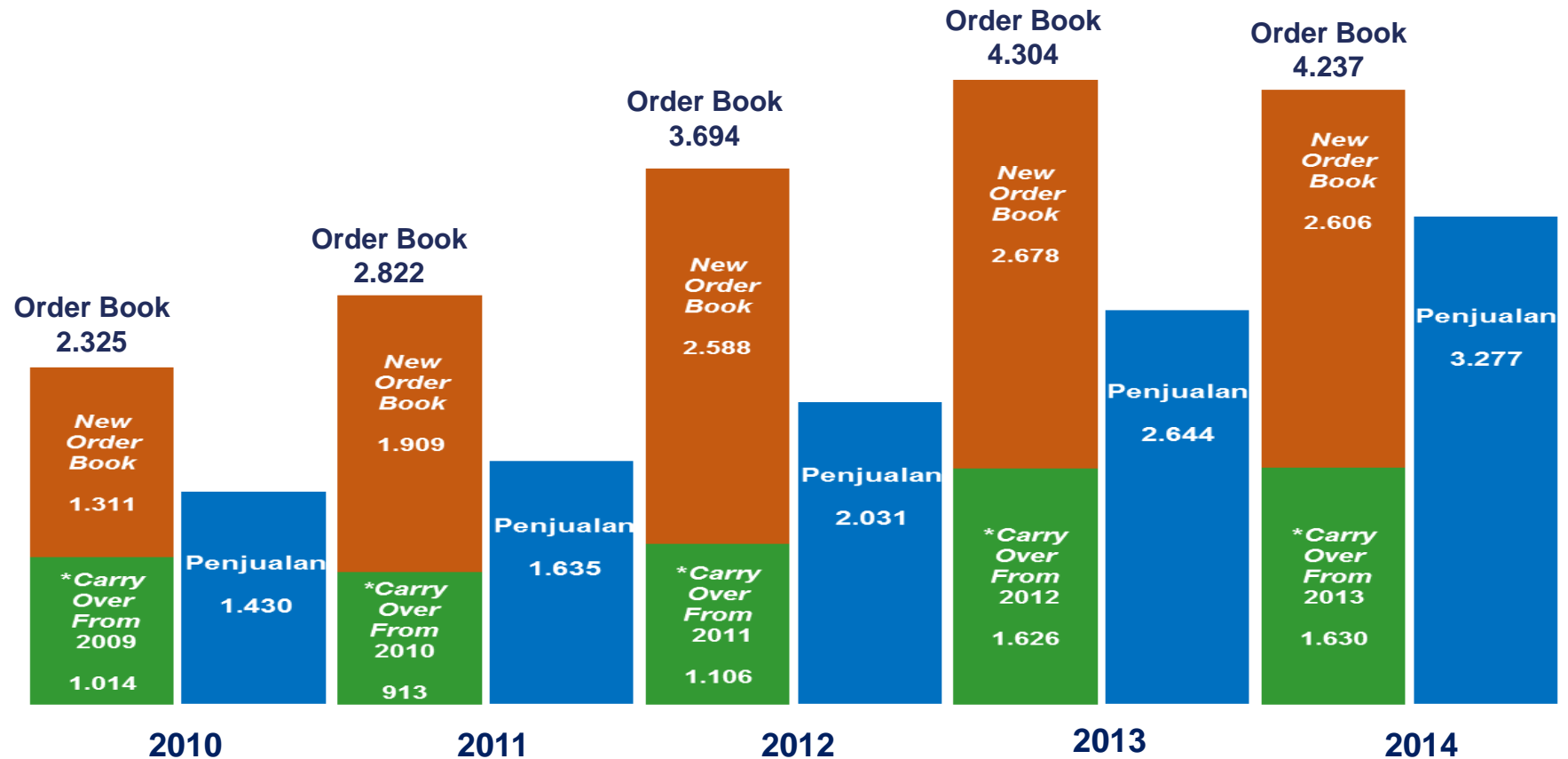

RINGKASAN LAPORAN LABA RUGI

Pendapatan (Rp Miliar)

Laba Kotor (Rp Miliar)

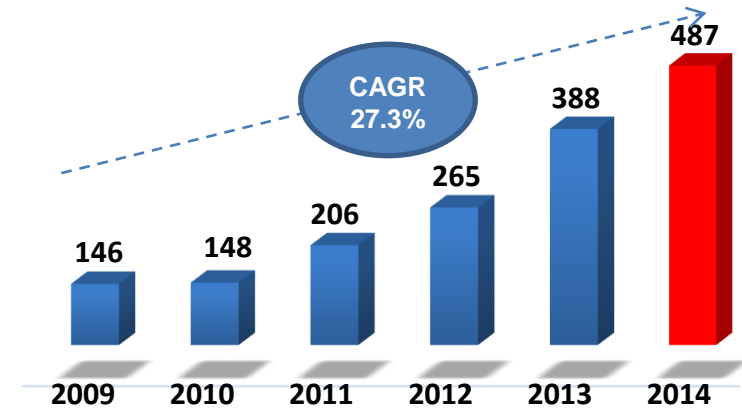
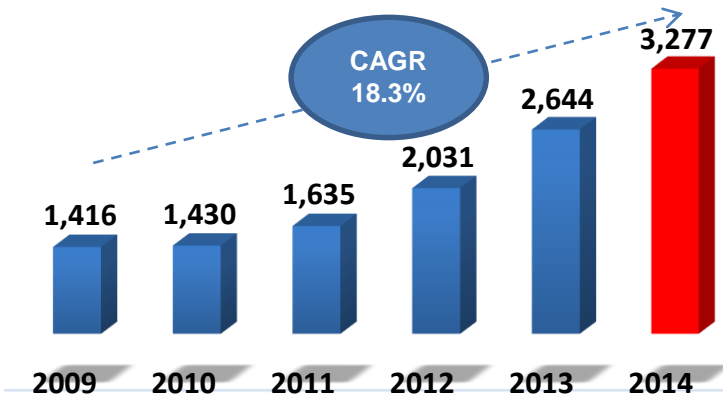

Laba Usaha (Rp Miliar)

Laba Bersih (Rp Miliar)

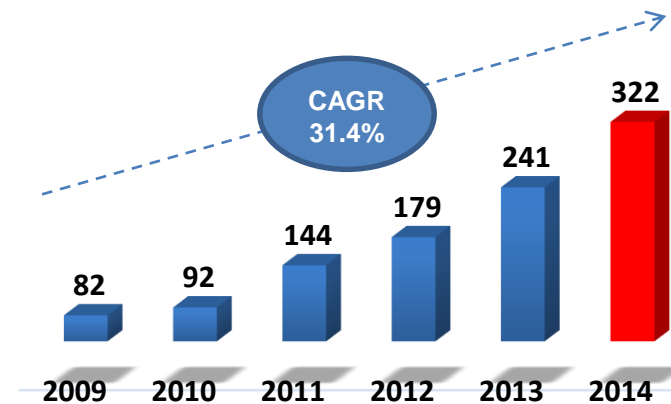
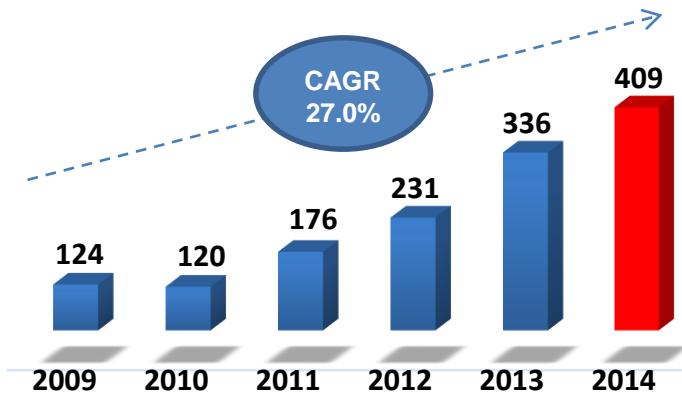

KONTRIBUSI PENJUALAN

- Wilayah Penjualan III DKI Jakarta memberikan kontribusi penjualan terbesar dengan rata-rata 26% diikuti dengan Wilayah Penjualan V Jawa Timur dengan 20% di 2011 – 2014.
- Tiang pancang mendominasi penjualan dengan rata-rata 54% diikuti Tiang Beton dari 2011 – 2014

Kontribusi Penjualan Berdasarkan Wilayah Penjualan

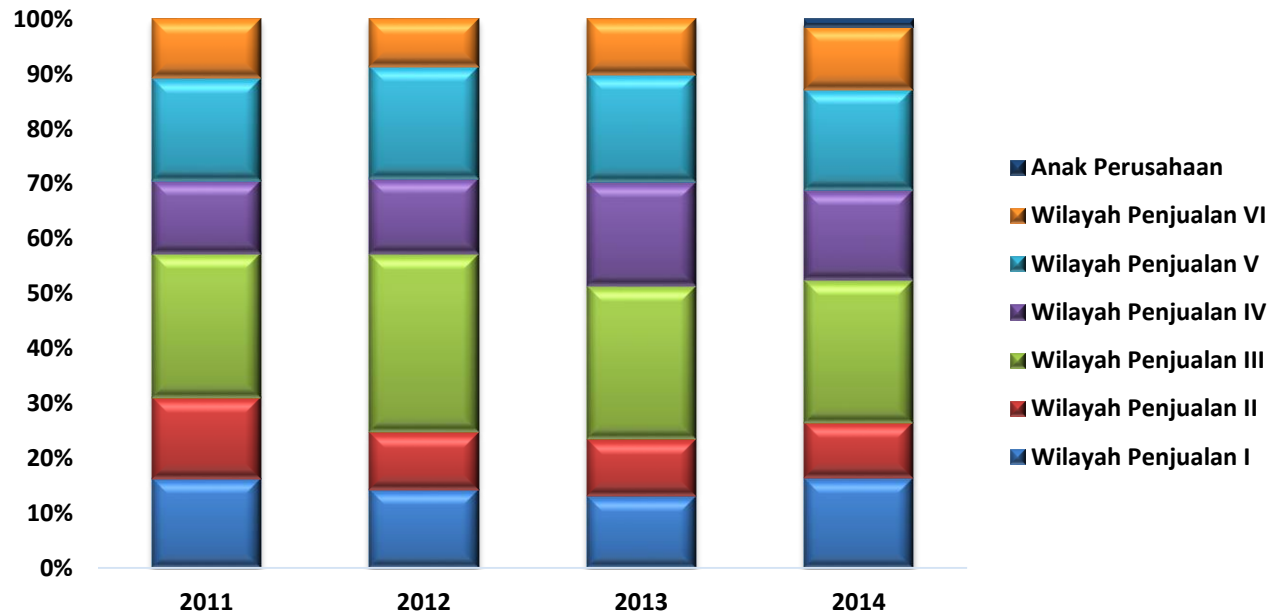

Sumber: Laporan Keuangan (Audited)

LAPORAN LABA RUGI, Full Year 2012-2014

	FY 2012		FY 2013		FY 2014	
	Real	%AV	Real	%AV	Real	%AV
NEW CONTRACT	-		-		2,606.4	
REVENUE	2,030.6	100.0%	2,643.7	100.0%	3,277.2	100.0%
% yoy			30.2%		24.0%	
COST OF SALES	(1,765.1)	-86.9%	(2,255.7)	-85.3%	(2,790.1)	-85.1%
Gross Profit Margin	265.5	13.1%	388.0	14.7%	487.1	14.9%
OPERATING EXPENSE	34.2	1.7%	51.8	2.0%	78.2	2.4%
Operating Profit Margin	231.3	11.4%	336.2	12.7%	408.9	12.5%
OTHER INCOME (EXPENSE)	2.4	0.1%	(7.7)	-0.3%	2.6	0.1%
Earning Before Tax	233.7	11.5%	328.5	12.4%	411.5	12.6%
INCOME TAX	(54.3)	-2.7%	(87.3)	-3.3%	(89.1)	-2.7%
Earning After Tax	179.4	8.8%	241.2	9.1%	322.4	9.8%
% yoy			34.4%		33.7%	

PENGGUNAAN DANA IPO

No	Uraian	Alokasi Rencana Penggunaan	s.d 31 Des 2014
A	PENGEMBANGAN USAHA (85%)		
	1 Pengolahan <i>Quarry</i> material alam di Cigudeg, Donggala, Boyolali dan Lampung Selatan	12%	46.1%
	2 Pabrik Baru di Lampung Selatan, Pasuruan dan Kalimantan	34%	37.6%
	3 Penambahan Kapasitas Pabrik <i>existing</i> di PPB Sumatera Utara, Lampung, Bogor, Karawang, Majalengka, Boyolali, Sulawesi Selatan dan Cetakan Produk	18%	39.3%
	4 Pengembangan usaha Jasa yaitu pembelian alat pancang <i>inner boring</i> dan penambahan alat <i>post tensioning</i>	18%	47.4%
	5 Pembentukan Unit Perbengkelan (<i>mould maker</i>)	3%	0.0%
B	MODAL KERJA (15%)		
	Tambahan Modal Kerja	15%	100.0%
		100%	

Total Penggunaan Dana IPO s.d 31 Des 2014 : 48,9%

RINGKASAN NERACA

Aset (Rp Miliar)

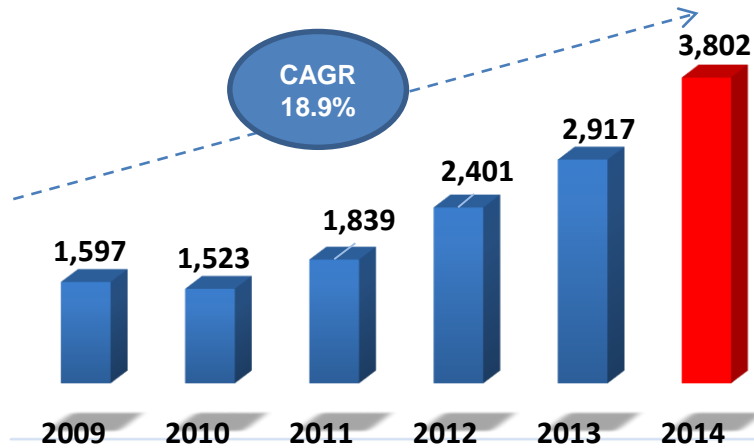

Liabilitas (Rp Miliar)

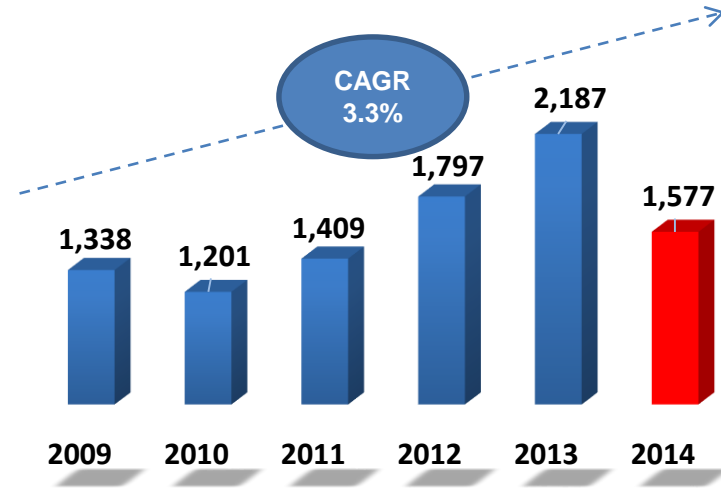

Ekuitas (Rp Miliar)

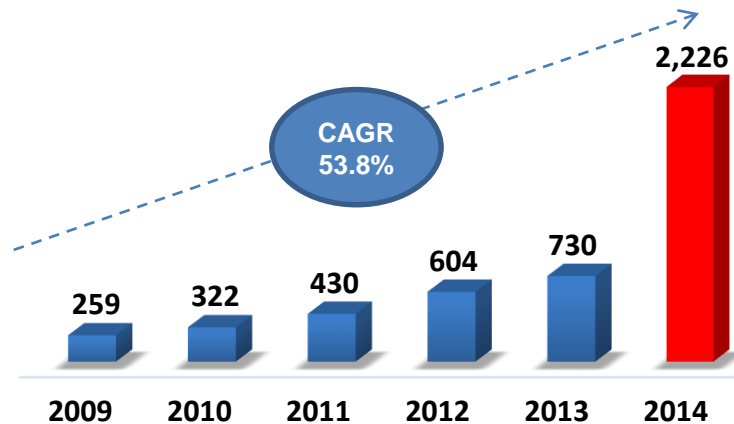

Current Ratio (x) & Quick Ratio (x)

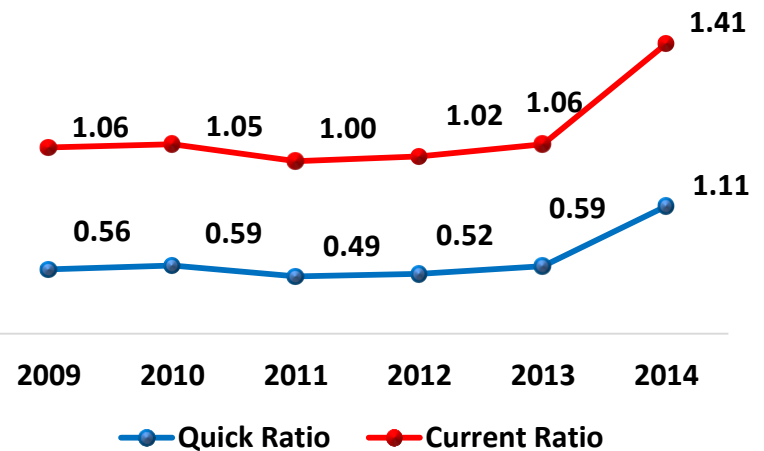

RASIO KEUANGAN DAN PROFITABILITAS

Profit Margin

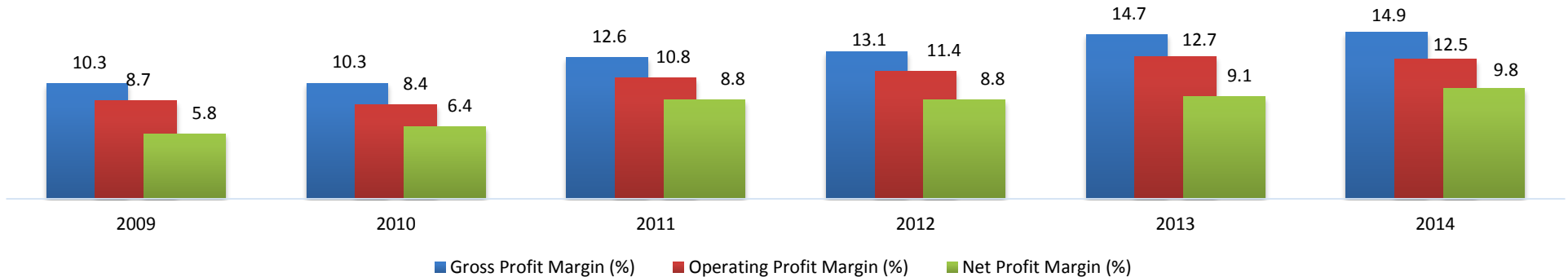

Return on Asset (ROA) and Return on Equity (ROE)

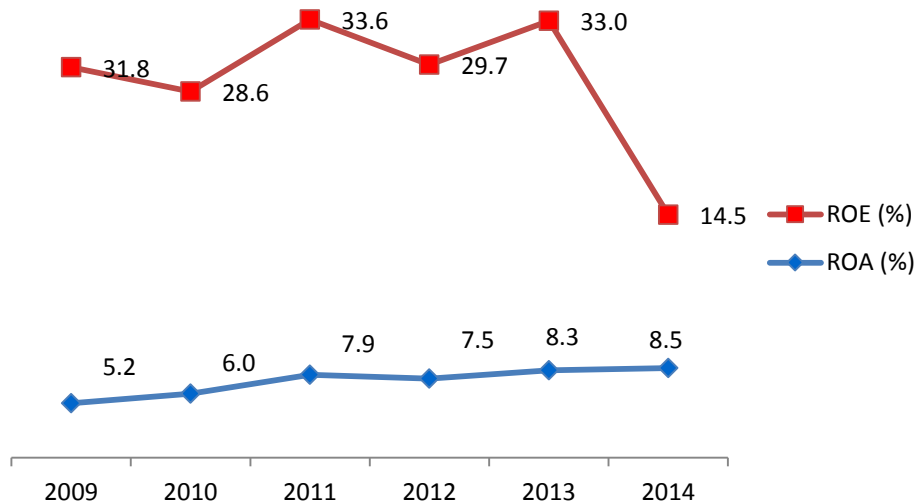

Gearing Ratio (Equity)

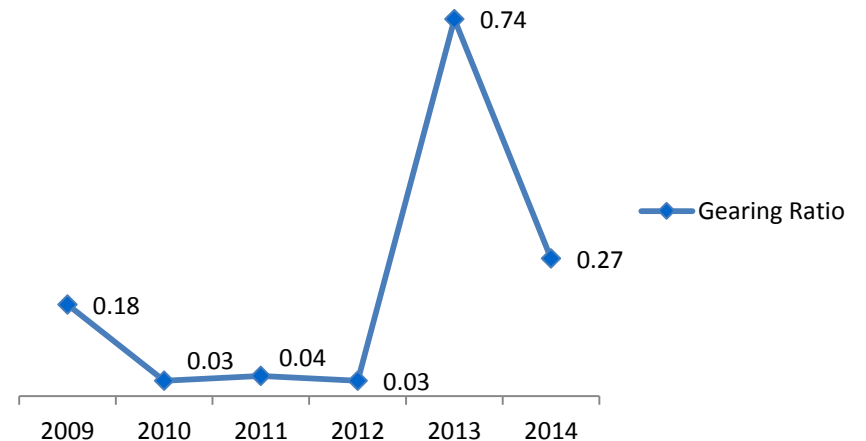



5

INFO TERKINI PERUSAHAAN

INFO TERKINI PERUSAHAAN

A. QUARRY CIGUDEG – JAWA BARAT

- Luas area 36,7 Ha
- Waktu pengerjaan proyek 6 bulan
- Kapasitas produksi 350 ton per jam
- Mulai beroperasi pada 29 Jan 2015
- Nilai investasi : Rp 113 Miliar



INFO TERKINI PERUSAHAAN

B. PABRIK LAMPUNG SELATAN (1/2)

- Luas area 67 Ha
 - Quarry 41 Ha
 - Pabrik 26 Ha
- Progress fisik pembangunan pabrik :
 - Perataan tanah 95%
 - Instalasi mesin & pembangunan prasarana Jetty
- Produksi : Cylinder Pile diameter hingga 2 meter dan panjang hingga 100 meters.
- Tahap 1 : 2 jalur produksi Cylinder Pile
- Tahap 2 : 2 jalur produksi Cylinder Pile

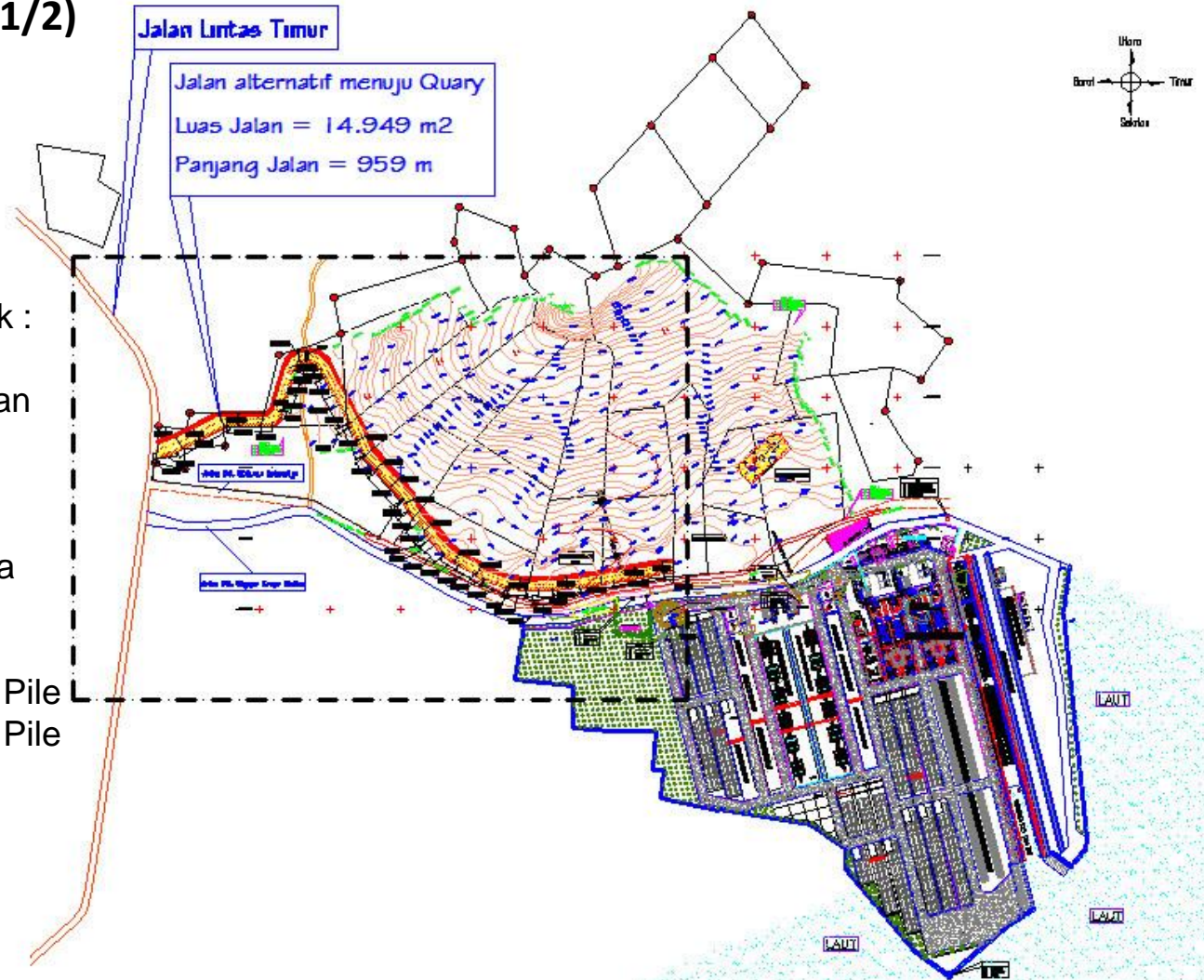

INFO TERKINI PERUSAHAAN

B. PABRIK LAMPUNG SELATAN (2/2)



INFO TERKINI PERUSAHAAN

C. PROYEK BERJALAN (1/2)



Apartemen Gold Coast dan Proyek Golf Island di Pantai Indah Kapuk



Proyek Reklamasi Agung Sedayu Group



Proyek PT OKI Pulp & Papers Mill di Sei Baung OKI

INFO TERKINI PERUSAHAAN

C. PROYEK BERJALAN (2/2)



Proyek Jembatan Dompok di Kepulauan Riau



Proyek Pembangunan Pabrik Oleochemical di Dumai, Riau



ANALYST REPORT

No	Analyst	Perusahaan	Target Harga (Rp)	Maintain	Tanggal
1	Martha Christina	Phillip Capital Securities	1,420	Buy	2 Apr 2015
2	Theodorus ArielKristian	Lautandhana Securindo	1,450	Buy	19 Mar 2015
3	Joko Sogie	Danareksa Sekuritas	1,350	Hold	10 Mar 2015
4	Deidy Wijaya	DBS Vickers Securities Indonesia	1,600	Buy	26 Jan 2015
5	Maxi Liesaputra	Sucorinvest Central Gani	1,550	Buy	19 Jan 2015
6	Arief Budiman	Ciptadana Securities	1,725	Buy	16 Jan 2015
7	Handoko Wijoyo	Mandiri Sekuritas	1,600	Buy	6 Jan 2015
8	Rachel Tan	Credit Suisse Malaysia	1,345	Buy	27 Nov 2014
9	Dian Octiana	Buana Capital Securities	1,120	Hold	22 Oct 2014
10	Yualdo Tirtakencana Yudoprawiro	RHB-OSK Securities	1,260	Buy	20 Oct 2014
11	Danny Eugene	Mega Capital Indonesia	1,300	Buy	18 Sep 2014

KINERJA SAHAM

Price

Volume (mn)

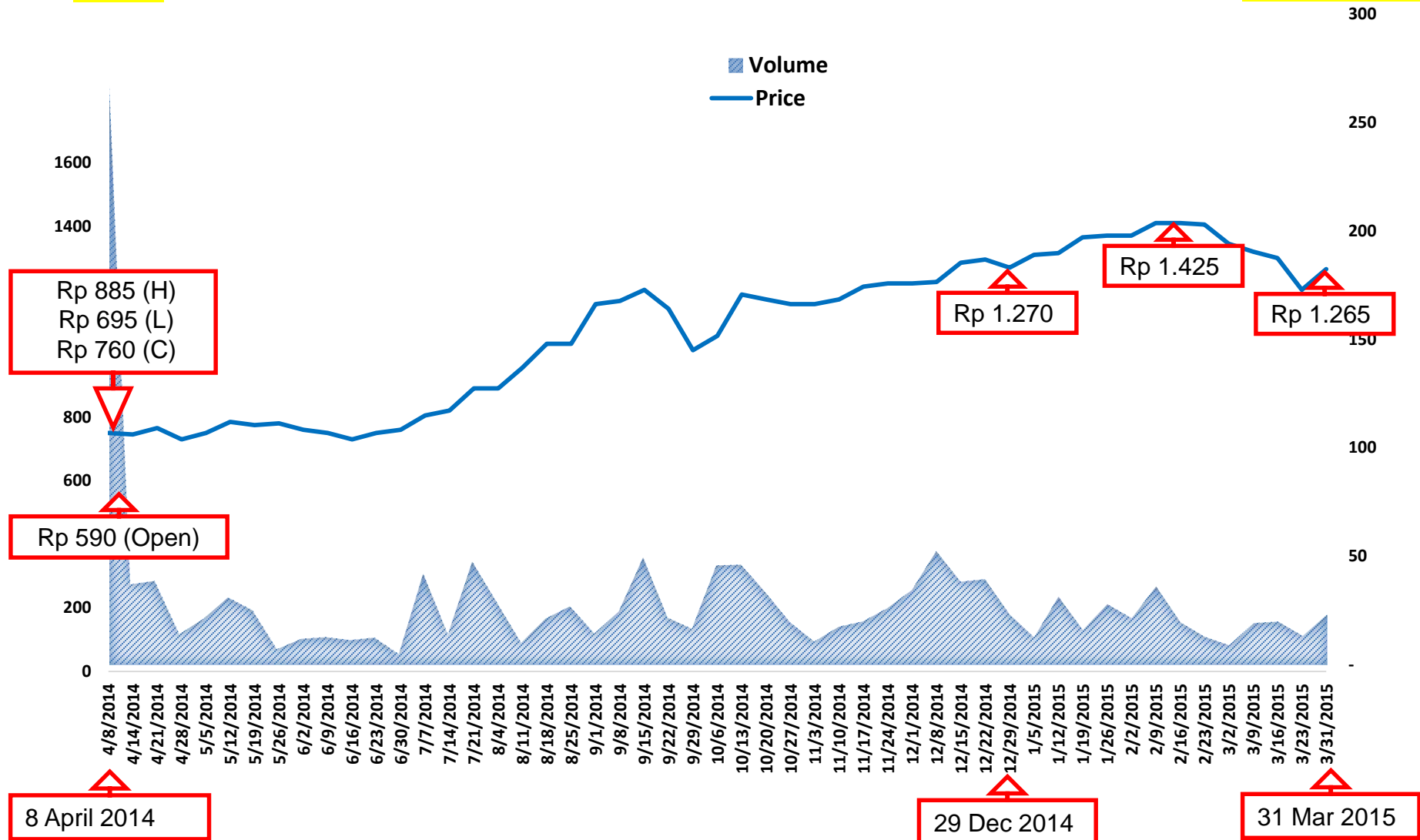

PENGHARGAAN & PENCAPAIAN (1/2)



SMK3



SNI



Thiess



Audit Certificate



ISO 9001:2008

PENGHARGAAN & PENCAPAIAN(2/2)



Best IPO Deal of The Year 2014 in Southeast Asia dan Best IPO of The Year 2014 in Southeast Asia For Retail Investors dari Alpha Southeast Asia



WTON as part of Morgan Stanley Capital Index (MSCI) started on 07 Nov 2014



Fastest Growing Issuer 2015 - Cement Category by Warta Ekonomi Indonesia Magazine



Best Employers 2015 by AON Hewitt Indonesia

KEGIATAN PERUSAHAAN

Program CSR – Kutaneegara, Karawang, Jawa Barat



WIKABeton menanam 13,851 bibit pohon di tahun 2014



Sanitasi air bersih dan MCK untuk masyarakat umum

CSR Program – Scholarship and Education Program



WIKABeton goes to campus - ITB



WIKABeton goes to campus - UNSRI

KEGIATAN PERUSAHAAN

RAPAT UMUM PEMEGANG SAHAM TAHUNAN TAHUN BUKU 2014

Agenda Rapat Umum Pemegang Saham Tahunan Tahun Buku 2014 :

1. Persetujuan Laporan Tahunan Perseroan Tahun 2014 termasuk di dalamnya Laporan Kegiatan Perseroan, Laporan Pengawasan Dewan Komisaris serta Pengesahan Laporan Keuangan Perseroan yang berakhir pada tanggal 31 Desember 2014.
2. Penetapan Penggunaan Laba Bersih termasuk pembagian dividen untuk Tahun Buku 2014.
3. Penunjukan Kantor Akuntan Publik untuk mengaudit Laporan Keuangan Perseroan Tahun Buku 2015.
4. Penetapan Gaji dan Tunjangan Lainnya bagi Anggota Dewan Komisaris dan Direksi Perseroan untuk tahun 2015 dan Tantiem untuk tahun buku 2014.
5. Perubahan Anggaran Dasar Perseroan
6. Penjaminan Aset Perseroan.
7. Perubahan Pengurus Perseroan.



END OF PRESENTATION

PT WIJAYA KARYA BETON Tbk

Head Office

Jl. Raya Jatiwaringin no. 54
Pondok Gede-Bekasi 17411

Contact Information

Phone : (+6221) 84973363
Fax : (+6221) 84973391, 84973392
Email : wbcc@wika-beton.co.id
marketing@wika-beton.co.id